

TO-220-3L Plastic-Encapsulate Transistors

2SB1185 TRANSISTOR (PNP)

FEATURES

- Low Collector Saturation Voltage
- Complement to Type 2SD1762

APPLICATIONS

- For Use in Low Frequency Power Amplifier Applications

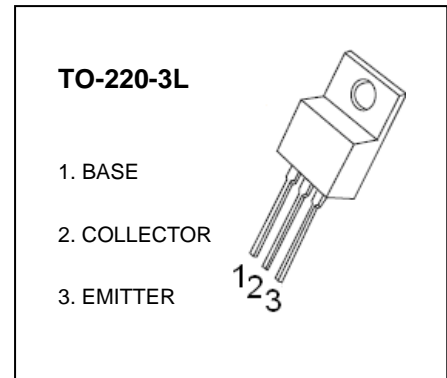

MAXIMUM RATINGS ($T_a=25^\circ\text{C}$ unless otherwise noted)

Symbol	Parameter	Value	Unit
V_{CBO}	Collector-Base Voltage	-60	V
V_{CEO}	Collector-Emitter Voltage	-50	V
V_{EBO}	Emitter-Base Voltage	-5	V
I_C	Collector Current	-3	A
P_C	Collector Power Dissipation	2	W
$R_{\theta JA}$	Thermal Resistance From Junction To Ambient	63	$^\circ\text{C/W}$
T_j	Junction Temperature	150	$^\circ\text{C}$
T_{stg}	Storage Temperature	-55~+150	$^\circ\text{C}$

ELECTRICAL CHARACTERISTICS ($T_a=25^\circ\text{C}$ unless otherwise specified)

Parameter	Symbol	Test conditions	Min	Typ	Max	Unit
Collector-base breakdown voltage	$V_{(BR)CBO}$	$I_C=-50\mu\text{A}, I_E=0$	-60			V
Collector-emitter breakdown voltage	$V_{(BR)CEO}$	$I_C=-1\text{mA}, I_B=0$	-50			V
Emitter-base breakdown voltage	$V_{(BR)EBO}$	$I_E=-50\mu\text{A}, I_C=0$	-5			V
Collector cut-off current	I_{CBO}	$V_{CB}=-40\text{V}, I_E=0$			-1	μA
Emitter cut-off current	I_{EBO}	$V_{EB}=-4\text{V}, I_C=0$			-1	μA
DC current gain	h_{FE}	$V_{CE}=-3\text{V}, I_C=-0.5\text{A}$	60		320	
Collector-emitter saturation voltage	$V_{CE(sat)}$	$I_C=-2\text{A}, I_B=-0.2\text{A}$			-1	V
Base-emitter saturation voltage	$V_{BE(sat)}$	$I_C=-2\text{A}, I_B=-0.2\text{A}$			-1.5	V
Collector output capacitance	C_{ob}	$V_{CB}=-10\text{V}, I_E=0, f=1\text{MHz}$		50		pF
Transition frequency	f_T	$V_{CE}=-5\text{V}, I_C=-0.5\text{A}, f=30\text{MHz}$		70		MHz

*Pulse test

CLASSIFICATION OF h_{FE}

RANK	D	E	F
RANGE	60-120	100-200	160-320

TO-220-3L Package Outline Dimensions

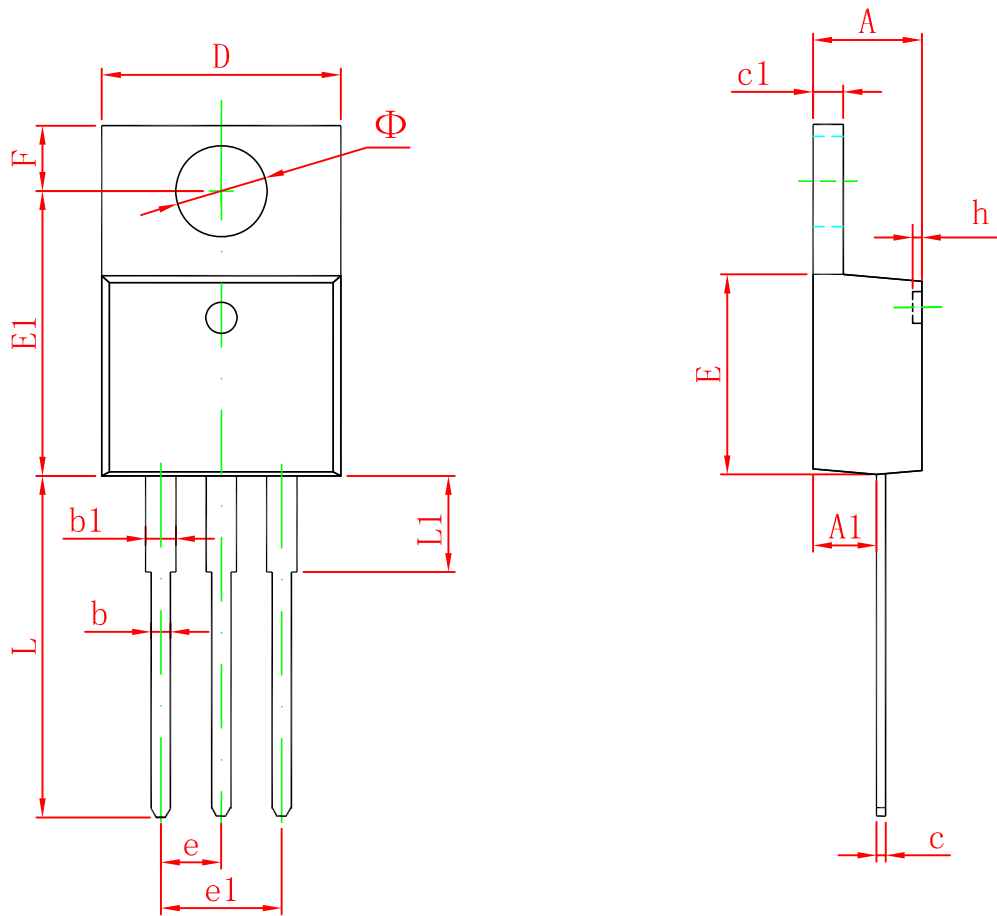

Symbol	Dimensions In Millimeters		Dimensions In Inches	
	Min	Max	Min	Max
A	4.470	4.670	0.176	0.184
A1	2.520	2.820	0.099	0.111
b	0.710	0.910	0.028	0.036
b1	1.170	1.370	0.046	0.054
c	0.310	0.530	0.012	0.021
c1	1.170	1.370	0.046	0.054
D	10.010	10.310	0.394	0.406
E	8.500	8.900	0.335	0.350
E1	12.060	12.460	0.475	0.491
e	2.540 TYP		0.100 TYP	
e1	4.980	5.180	0.196	0.204
F	2.590	2.890	0.102	0.114
h	0.000	0.300	0.000	0.012
L	13.400	13.800	0.528	0.543
L1	3.560	3.960	0.140	0.156
Φ	3.735	3.935	0.147	0.155