

**TO-251-3L Plastic-Encapsulate Transistors**

**2SA1242** TRANSISTOR (PNP)

**FEATURES**

- Strobe Flash Applications Medium Power Amplifier Applications
- Excellent  $h_{FE}$  Linearity  
 :  $h_{FE(1)} = 100$  to  $320$  ( $V_{CE} = -2$  V,  $I_C = -0.5$  A)  
 :  $h_{FE(2)} = 70$  (min) ( $V_{CE} = -2$  V,  $I_C = -4$  A)
- Low Collector Saturation Voltage  
 :  $V_{CE(sat)} = -1.0$  V (max) ( $I_C = -4$  A,  $I_B = -0.1$  A)
- High Power Dissipation  
 :  $P_C = 10$  W ( $T_c = 25^\circ\text{C}$ ),  $P_C = 1.0$  W ( $T_a = 25^\circ\text{C}$ )

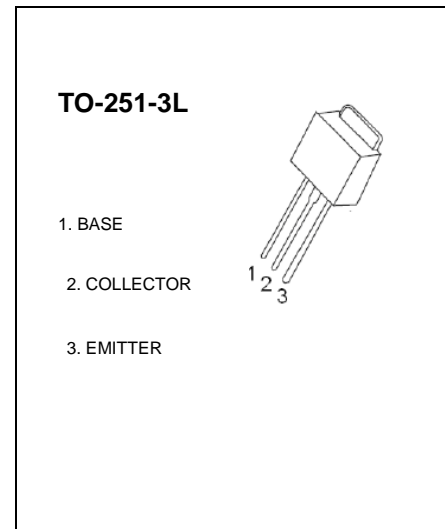

**MAXIMUM RATINGS** ( $T_a=25^\circ\text{C}$  unless otherwise noted)

Symbol	Parameter	Value	Unit
$V_{CBO}$	Collector-Base Voltage	-35	V
$V_{CEO}$	Collector-Emitter Voltage	-20	V
$V_{EBO}$	Emitter-Base Voltage	-8	V
$I_C$	Collector Current -Continuous	-5	A
$P_C$	Collector Power Dissipation	1	W
$T_J$	Junction Temperature	150	$^\circ\text{C}$
$T_{stg}$	Storage Temperature	-55 to +150	$^\circ\text{C}$

**ELECTRICAL CHARACTERISTICS** ( $T_a=25^\circ\text{C}$  unless otherwise specified)

Parameter	Symbol	Test conditions	Min	Typ	Max	Unit
Collector-base breakdown voltage	$V_{(BR)CBO}$	$I_C=-100\mu\text{A}$ , $I_E=0$	-35			V
Collector-emitter breakdown voltage	$V_{(BR)CEO}$	$I_C=-1\text{mA}$ , $I_B=0$	-20			V
Emitter-base breakdown voltage	$V_{(BR)EBO}$	$I_E=-100\mu\text{A}$ , $I_C=0$	-8			V
Collector cut-off current	$I_{CBO}$	$V_{CB}=-35\text{V}$ , $I_E=0$			-100	nA
Emitter cut-off current	$I_{EBO}$	$V_{EB}=-8\text{V}$ , $I_C=0$			-100	nA
DC current gain	$h_{FE(1)}$	$V_{CE}=-2\text{V}$ , $I_C=-0.5\text{A}$	100		320	
	$h_{FE(2)}$	$V_{CE}=-2\text{V}$ , $I_C=-4\text{A}$	70			
Collector-emitter saturation voltage	$V_{CE(sat)}$	$I_C=-4\text{A}$ , $I_B=-0.1\text{A}$			-1	V
Base-emitter voltage	$V_{BE}$	$V_{CE}=-2\text{V}$ , $I_C=-4\text{A}$			-1.5	V
Transition frequency	$f_T$	$V_{CE}=-2\text{V}$ , $I_C=-0.5\text{A}$		170		MHz
Collector output capacitance	$C_{ob}$	$V_{CB}=-10\text{V}$ , $I_E=0$ , $f=1\text{MHz}$		62		pF

**CLASSIFICATION OF  $h_{FE(1)}$**

Rank	0	Y
Range	100-200	160-320

# TO-251-3L Package Outline Dimensions

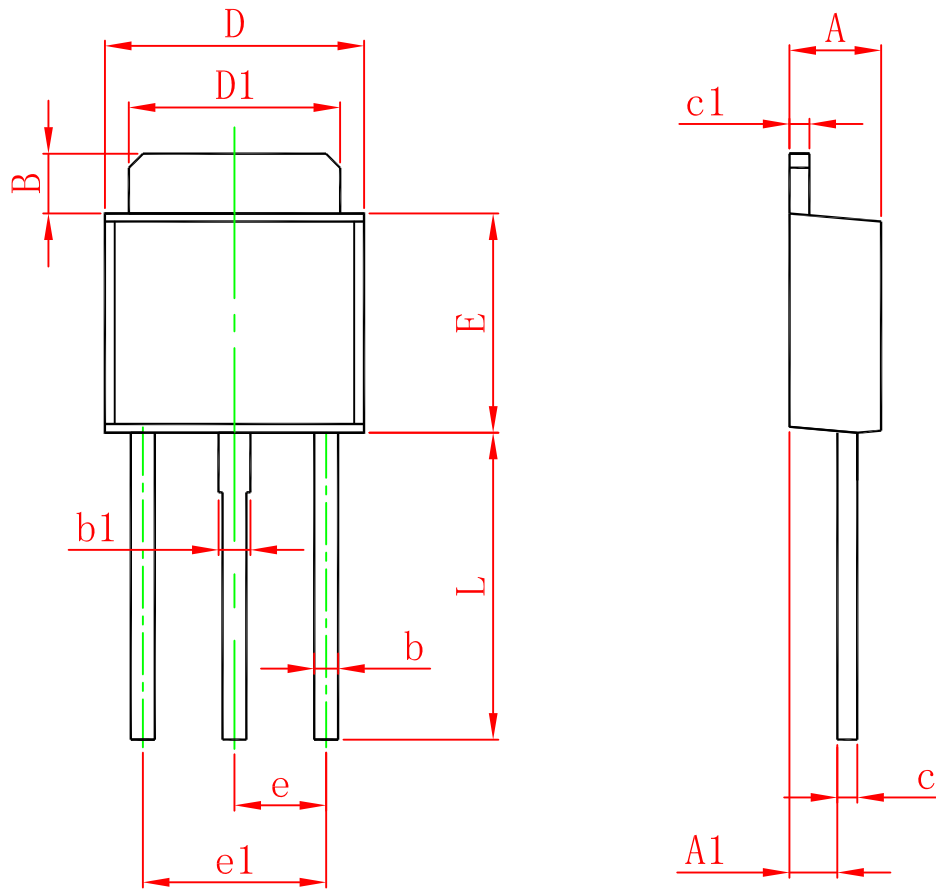

Symbol	Dimensions In Millimeters		Dimensions In Inches	
	Min.	Max.	Min.	Max.
A	2.200	2.400	0.087	0.094
A1	1.050	1.350	0.042	0.054
B	1.350	1.650	0.053	0.065
b	0.500	0.700	0.020	0.028
b1	0.700	0.900	0.028	0.035
c	0.430	0.580	0.017	0.023
c1	0.430	0.580	0.017	0.023
D	6.350	6.650	0.250	0.262
D1	5.200	5.400	0.205	0.213
E	5.400	5.700	0.213	0.224
e	2.300 TYP.		0.091 TYP.	
e1	4.500	4.700	0.177	0.185
L	7.500	7.900	0.295	0.311